

## STEEL AXLES

**We are the first in the world to pioneer the production of Hollow Axle with Close End** and one of the few manufacturers that are able to offer the complete range of solid and hollow axle product. of solid and hollow axle product.

- Material: Low Carbon Steel Din ST 37.2 (Q235b) or similar
- Zinc Coating Thickness: 10um – 60um
- Colour can be painted on both end of axle for identification purpose
- The axle are free of all burrs and sharp edges
- Option on Hollow Axle wall thickness: 1.8mm / 2.0mm / 2.5 mm
- Option for axle external diameter : 19mm / 21.5mm / 22mm or otherwise specify

Customisation is available. Please email your requirements to [sales@plasticmgb.com](mailto:sales@plasticmgb.com)

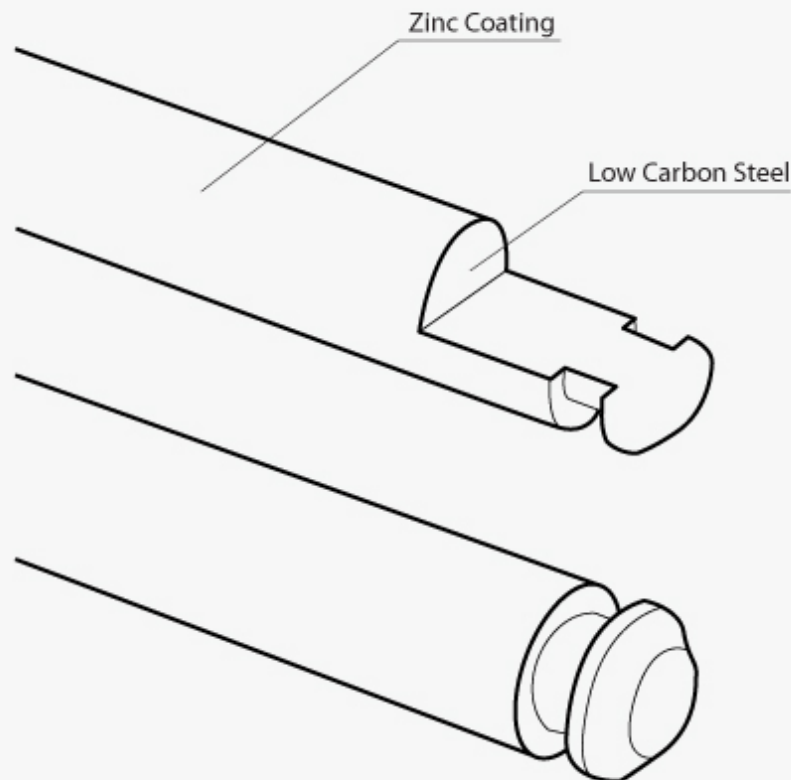

Solid Axle

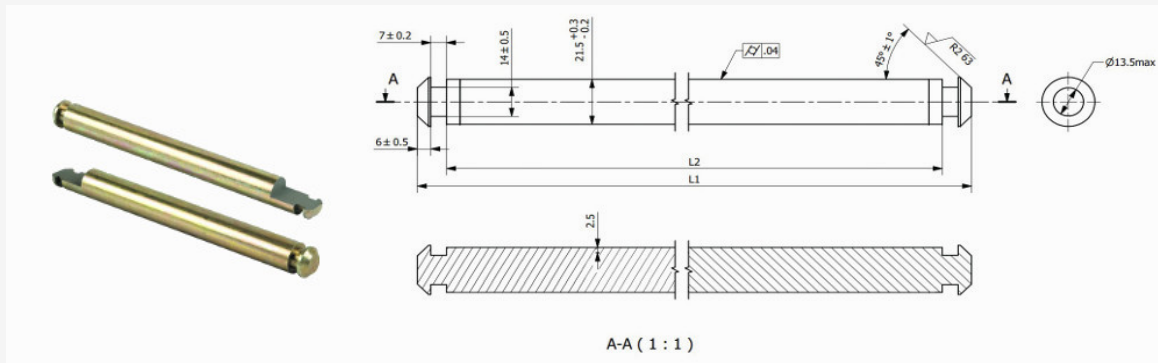

Semi Hollow Axle

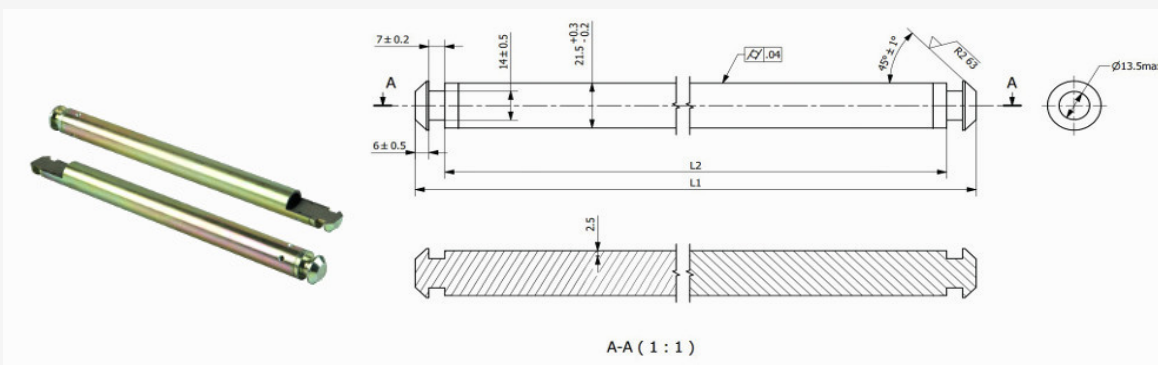

Full Hollow Axle with Open End

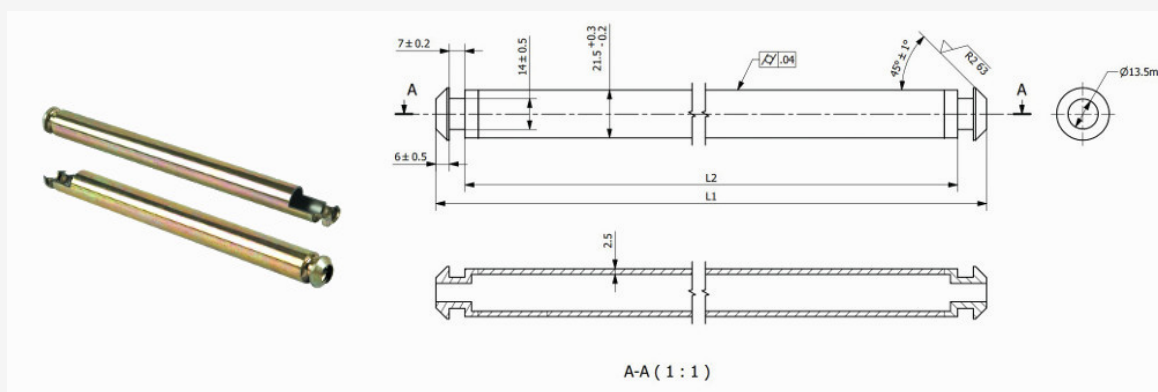

Full Hollow Axle with Closed End

